



## Ultrapure Water System HALIOS 6



HALIOS lab water systems make your work as pleasant and comfortable as possible and maximize at the same time your lab productivity

The HALIOS 6 lab water series is modular designed and can be connected directly to tap water. With an integrated 10l tank and a production rate of 6l/h it provides a high flexibility to adapt to your specific needs. Each system meets and exceeds ASTM type 1 and 2 standards. An integrated pre-treatment cartridge guarantees a long durability of the RO membrane and the following purification cartridges as well as a constant ideal ultrapure water quality for reproducible results of analysis. Interact only with your external tabletop dispenser. The compact production unit can be easily integrated in the lab environment.



## Features

- ✓ Reliable ultrapure water quality - ASTM type 1<sup>+</sup> and 2
- ✓ External dispenser
  - ◆ detachable and ergonomically shaped
  - ◆ rotatable and vertically adjustable
- ✓ Pre-treatment cartridge for a direct connection to tap water
- ✓ Simple and economical change of the consumables
- ✓ Large and intuitive touchscreen
- ✓ Leak water detector
- ✓ Pressure reducer
- ✓ Data capture via USB
- ✓ Accurate, adjustable volume dispensing
- ✓ Dry-run protection
- ✓ 10l tank with complete recirculation ensures the highest microbial purity
- ◆ ECO Mode to extend the cartridge life by up to 20%

## System configuration

- Wide-range power supply 80-264V / 50-60Hz
- Housing with an easily accessible service cover
- Compact production unit fits easily into various free spaces in the lab
- Exchange of consumables within seconds due to quick-connect couplings
- Integrated pressure reducer for different inlet pressures
- Flow meter for an accurate volume dispensing
- Pressure sensor for monitoring of the working pressure and as a dry-running protection
- Two low-noise and durable pressure and recirculation pumps for the complete internal recirculation of all wetted parts up to the final dispensing valve
- Integrated pre-treatment cartridge protects from impurities in the feedwater and protect the RO membrane as well as guarantees reproducible results of analysis, a high capacity and low operating costs
- RO membrane removes up to 99% of all impurities in the feed water
- Ultrapure water cartridge for the final removal of organics and remaining ions
- Up to three measuring cells for the exact measurement of the conductivity and temperature after each purification cartridge
- Flush valve for the effective cleaning of all wetted parts as well as an adjustable quality flush during stand-by
- Dispenser with microfiltration for the sterile ultrapure water withdrawal at the point of use
- 10l pure water tank with conical bottom and pure water (type 2) outlet



### Optional

- UV-unit (185 | 254nm) for the ultimate microbiological purity and TOC reduction
- Flushed and integrated ultrafiltration module for the retention of pyrogens, endotoxins, proteins and nucleases (DNases and RNases)
- Real-time TOC monitor for the continuous TOC measurement of the organic compound acc. to USP
- Up to 4 external dispensers can be connected to one production unit
- External pure water tanks in 30, 60 or 100l
- EDI module for residual desalination for a continuous quality improvement and lower running costs

## User interface

- Large and intuitive touchscreen
- Stored dispensing reports with all information ensure an absolute traceability of the water withdrawals
- Individual adjustment for displaying the conductivity ( $M\Omega\text{cm}$  or  $\mu\text{S}/\text{cm}$ )
- Multilevel conductivity and temperature monitoring for pure and ultrapure water, temperature compensated with stepless limit adjustments
- High-precision measuring with integrated reference resistors as well as deactivatable temperature compensation acc. to USP
- Leakage monitor with error message and automatic shut-off of the feed water supply
- Continuous surveillance of all relevant parameters and values incl. early reminders when a change of consumables is pending
- GLP-compliant data storage via USB
- ECO Mode to extend the cartridge life by up to 20%



## Tabletop dispenser

- Ergonomic design for a one-handed operation
- All dosing functions can be easily executed with the rotary encoder at the dispensing handle
- The external dispenser can be placed independent of the production unit
- For an even greater range the HALIOS handle can be detached and reattached with a simple hand movement



## Feed water requirements

|                            |                   |
|----------------------------|-------------------|
| Feed water quality         | Potable tap water |
| Conductivity at 25°C       | < 2000µS/cm       |
| Total organic carbon (TOC) | < 1ppm            |
| Inlet pressure*            | 1 – 6bar          |
| Temperature                | 5 – 35°C          |

*Additional pre-treatment units are available if the feed water is out of specs*

## Ultrapure water specifications (ASTM type 1)<sup>1</sup>:

|   |   |
|---|---|
| Resistivity (Conduct.) at 25°C <sup>2</sup> | 18.2MΩcm (0.055µS/cm)                                     |
| Total Organic Carbon <sup>3</sup> (TOC)     | ≤ 2ppb (µg/l)<br>≤ 10ppb (w/o option – UV lamp)           |
| Particle content <sup>4</sup>               | < 1/ml  |
| Bacteria                                    | < 0,01 CFU/ml <sup>4</sup><br>< 0,005 CFU/ml <sup>5</sup> |
| Pyrogens (endotoxins) <sup>5</sup>          | < 0,001 EU/ml   |
| RNases <sup>5</sup>                         | < 0,004ng/ml  |
| DNases <sup>5</sup>                         | < 0,024pg/µl  |
| Flow rate                                   | Up to 2l/min  |

## Pure water specifications in the tank (ASTM type 2)

|                                |                      |
|--------------------------------|----------------------|
| Resistivity (Conduct.) at 25°C | > 10MΩcm (<0,1µS/cm) |
| TOC                            | ≤ 30ppb (µg/l)       |
| Performance                    | 6l/h                 |

<sup>1</sup> *The actual values may vary depending on the nature and concentration of the contaminants in the feed water*

<sup>2</sup> *Conductivity/resistivity can also be displayed non-temperature compensated as required by USP*

<sup>3</sup> *In the appropriate operating conditions*

<sup>4</sup> *With sterile filter capsule at the POU*

<sup>5</sup> *With option – ultrafiltration module*

## Technical data

|                     |                   |
|---------------------|-------------------|
| Ambient temperature | +2 - 35°C         |
| Supply voltage      | 90-240V / 50-60Hz |
| Connected load      | 120W              |
| Connection size     | R ¾“              |

## Dimensions

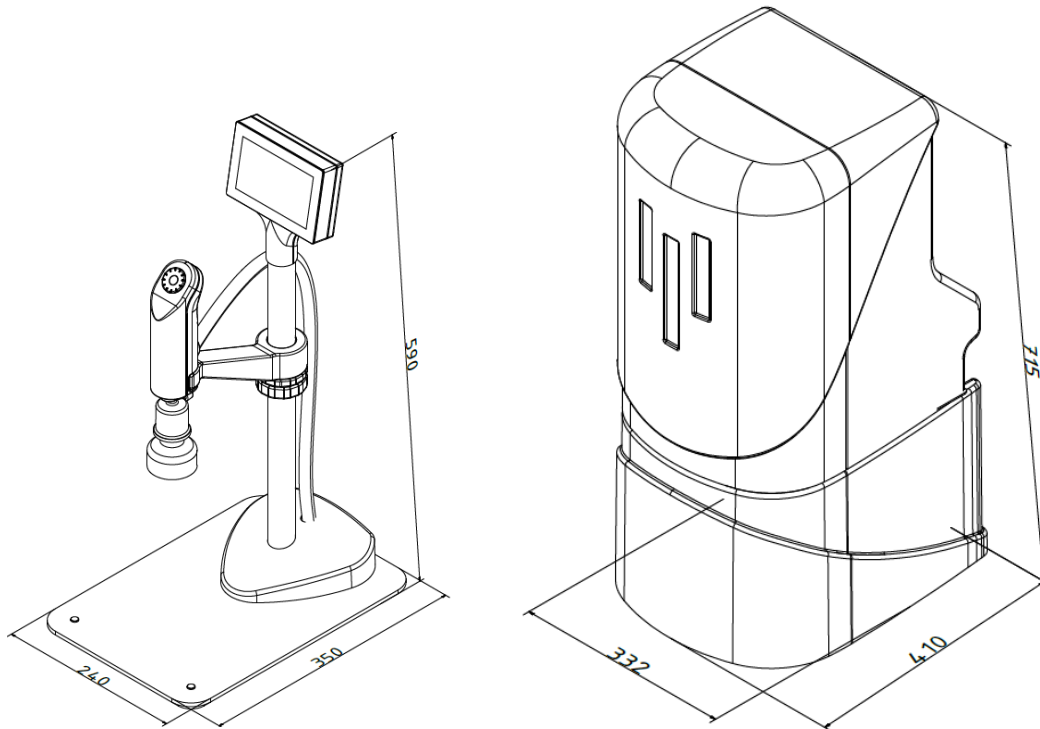

## Ordering information

### Lab water system

#### Catalogue Number

10000111

#### Description

Ultrapure water system HALIOS 6

#### Accessories / options

10000101

Option – UV lamp 185 | 254nm

10000102

Option – Ultrafiltration module

10000103

Option – TOC monitor

10000455

Option - EDI Modul

10000454

Wall mount for production unit and tank HALIOS 6 | 12

10000453

Wall mount for Dispenser HALIOS

10000430

Disinfection kit HALIOS incl. one disinfectant

10000104

Additional remote dispenser HALIOS  
(up to 3 additional)

10000340

Option – XXL Dispenser HALIOS (Height + 15cm)

10000341

Option - 4m connection between dispenser and  
production unit (instead of 1.5m standard)

**Zubehör / Optionen**

| <b>Bestellnummer</b> | <b>Beschreibung</b>  |
|----------------------|--|
| 10000367             | Water softener MixMulti WEA 25<br>(Recommended when feed water > 20°dH)  |
| 10000376             | Upgrade - Pure water tank 30l incl. level sensor, circulation pump, dispensing tap, sterile overflow and sterile vent filter + CO <sub>2</sub> Absorber  |
| 10000377             | Upgrade - Pure water tank 60l incl. level sensor, circulation pump, dispensing tap, sterile overflow and sterile vent filter + CO <sub>2</sub> Absorber  |
| 10000378             | Upgrade - Pure water tank 100l incl. level sensor, circulation pump, dispensing tap, sterile overflow and sterile vent filter + CO <sub>2</sub> Absorber |
| 10000456             | Option - UV tank disinfection for 30/60/100l tank  |
| 10000380             | Option – Pressure outlet for 30/60/100l tank 120l/h at 3 bar   |
| 10000480             | Option – External pressure pump 3m <sup>3</sup> /h at 3 bar  |
| 10000302             | Qualification documents HALIOS 6   12  |

**Consumables**

|          |  |
|----------|--|
| 10000113 | Pretreatment cartridge HALIOS RO-GUARD                           |
| 10000114 | RO membrane 6l/h   |
| 10000107 | Polishing cartridge HALIOS UPW 182                               |
| 10000110 | Replacement ultrafilter  |
| 10000108 | Replacement UV-lamp 185   245nm                                  |
| 10000109 | Sterile filter capsule 0.2µm                                     |
| 10000116 | Sterile vent filter 0.2µm  |
| 10000431 | Disinfectant HALIOS in a syringe<br>(Disinfection kit necessary) |